

Karimba Tunings offered by Kalimba Magic

The 17-Note Hugh Tracey Karimba can be tuned to a wide variety of tunings, and can even be rearranged into a Lotus, Air, or Freyghish karimba. This page focuses on the karimba tunings that are related to the body of traditional African karimba songs. The African tuning shown here has 3rd, 6th and 7th intervals (C#, F# and G#) that are tuned in between major and minor western intervals. If you want the African experience, try the African tuning. If your ear needs the western intervals, or if you are playing with guitar, piano, or other western tuned instruments, try the A major, A minor, or even G major or G minor tunings.

When you put an A major karimba and an A minor karimba in the hands of traditional players, they say the major tuning is closer to their preferred tuning. Indeed, if you play any of the traditional songs, they will sound just fine on the A Western or G Western tunings, but most will sound odd on the minor tunings. On the other hand, the minor tunings are great for peaceful new-age music.

Learn more about the karimba at:

www.kalimbamagic.com/karimba

Learn about tuning your karimba at:

www.kalimbamagic.com/tuning

A African Tuning

Notes, and cents flat (-) or sharp (+)

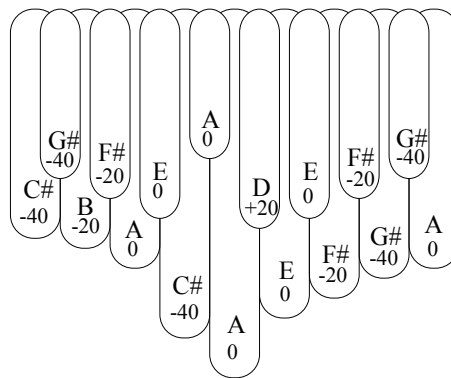

A Western Tuning - A major

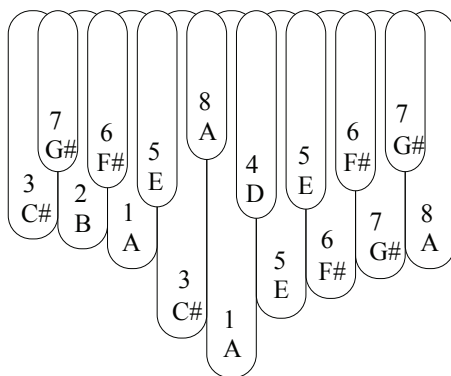

A Minor Tuning Works with C major

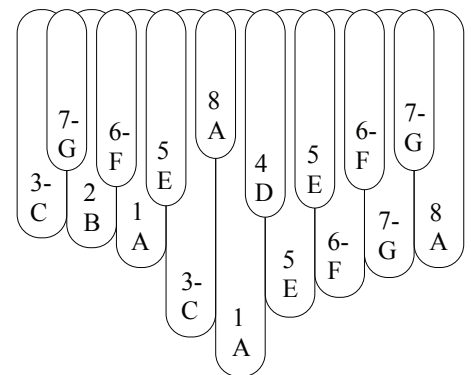

The numbers above the note names indicate the “degree of the scale” - that is, 1 is “Do” the root note; 2 is “Re” the second note of the scale; 3 is “Mi” the third, and 3- is a minor third, halfway between “Re” and “Mi”.

G Western Tuning - G major Works with Alto, Treble

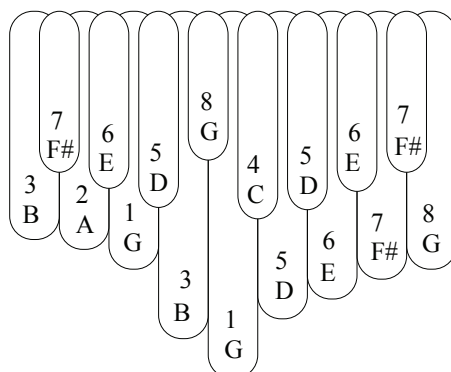

G Minor Tuning works with Bb Treble, Lotus Karimba

